

ASHFORD TRADITIONAL SPINNING WHEEL SINGLE DRIVE

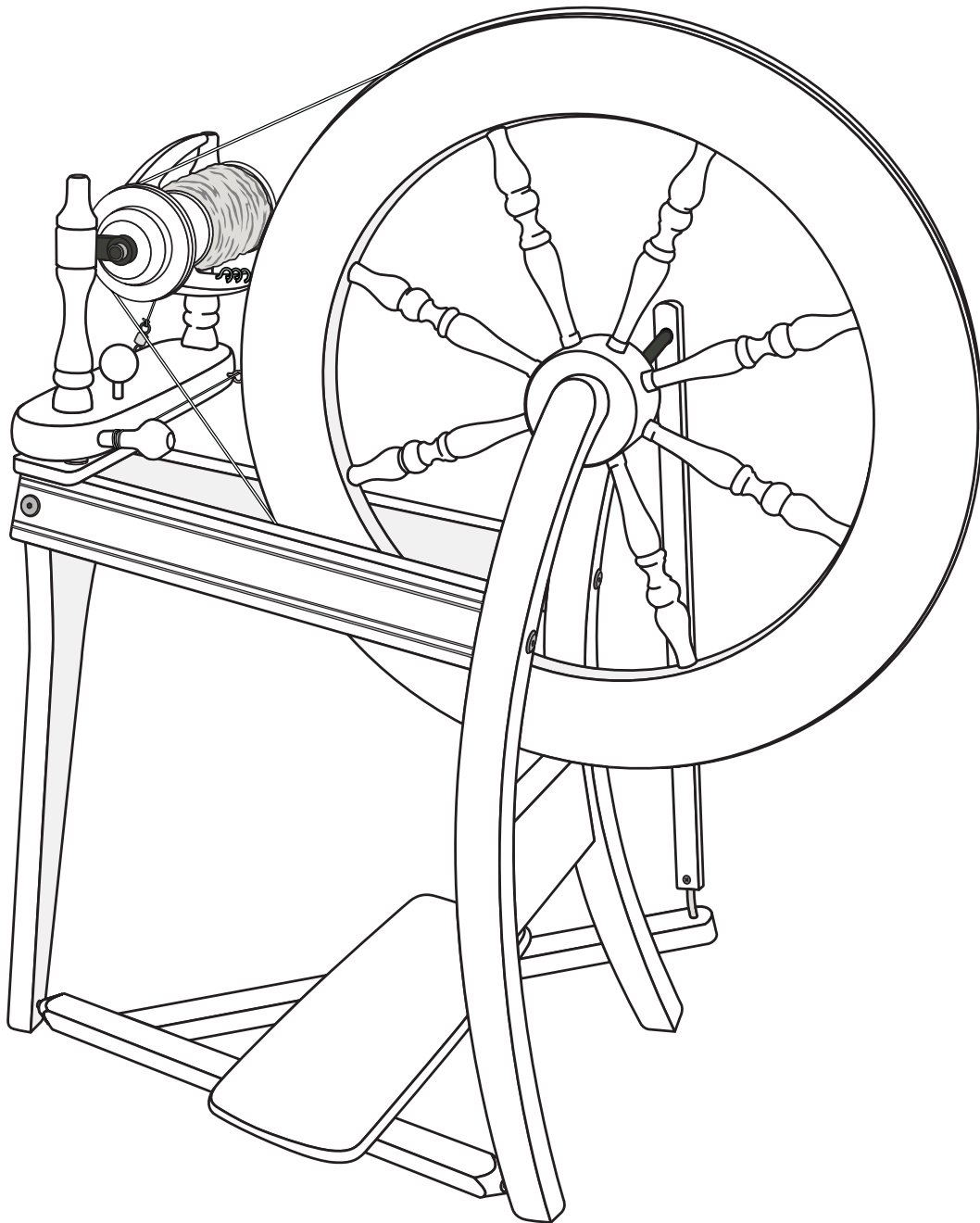

ASSEMBLY INSTRUCTIONS FOR THE ASHFORD TRADITIONAL SPINNING WHEEL

-Single Drive-

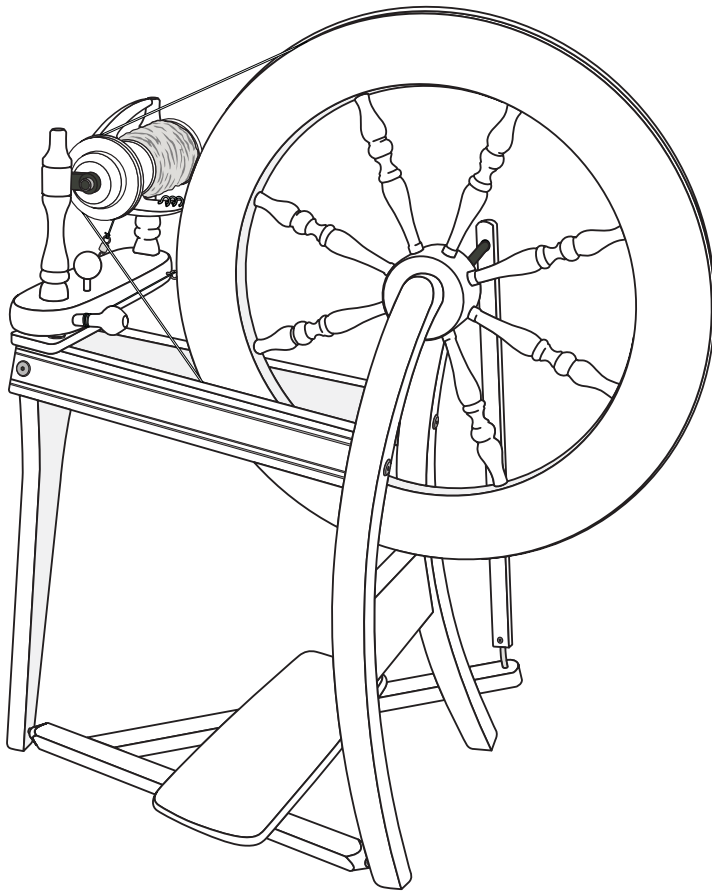

TOOLS



Screwdriver

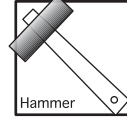

Hammer



Scissors



OIL



CANDLE WAX

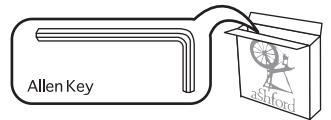

Allen Key

HINT 1

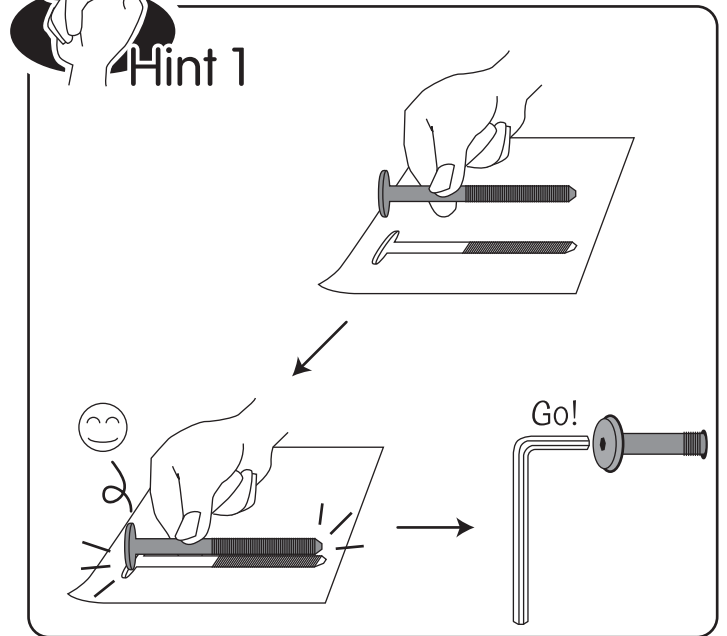

HINT 2

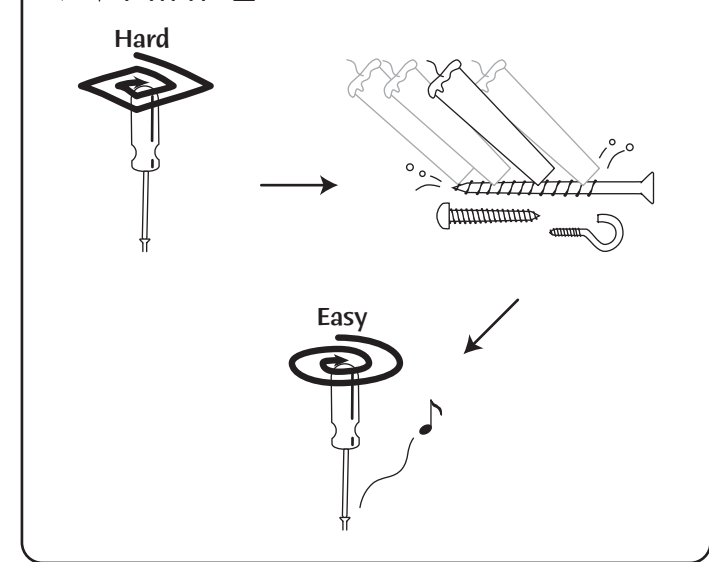

HINT 3

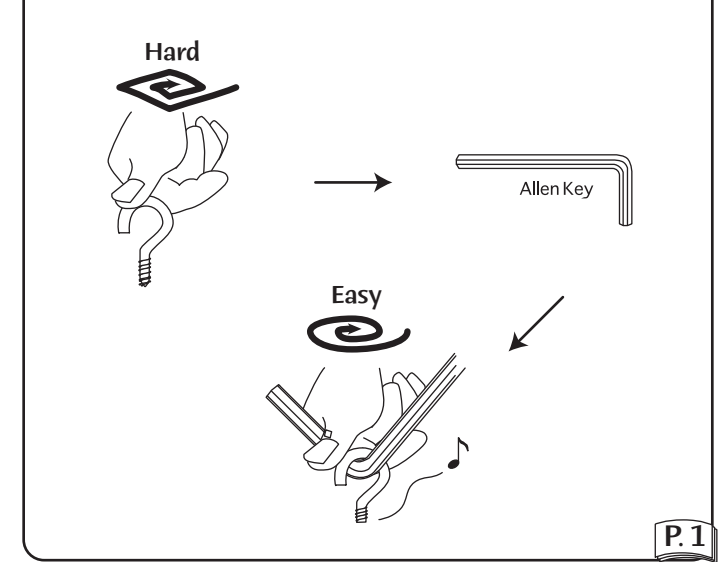

1

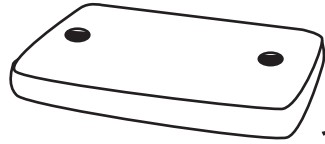
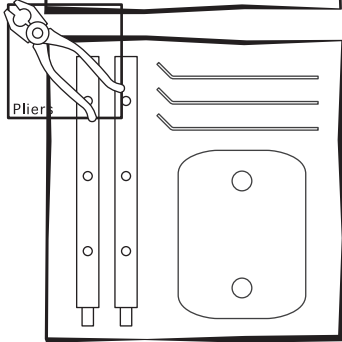
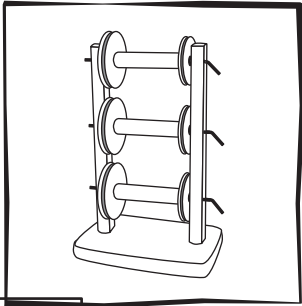

1.

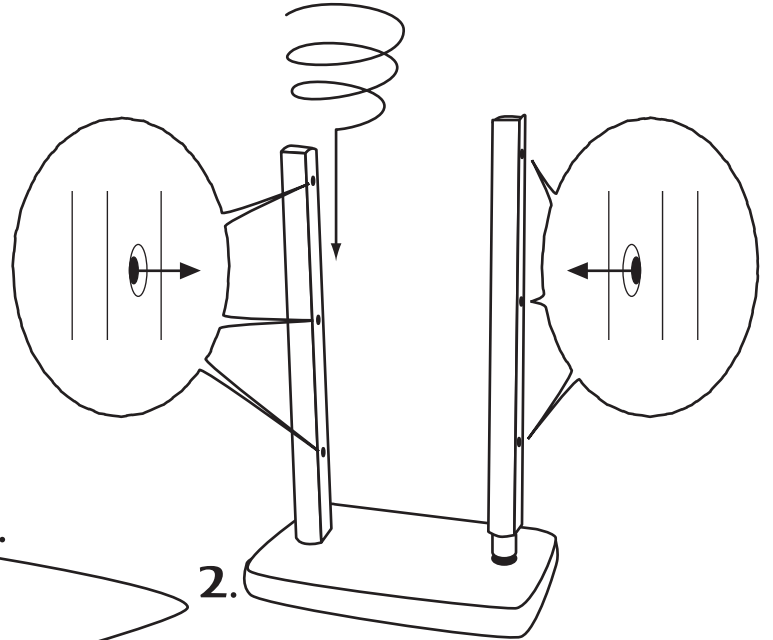

2.

3.

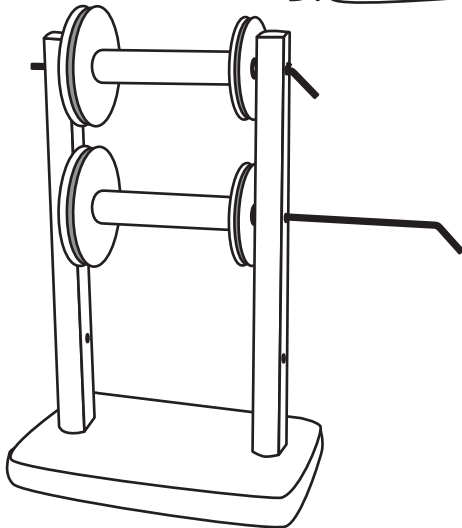

4.

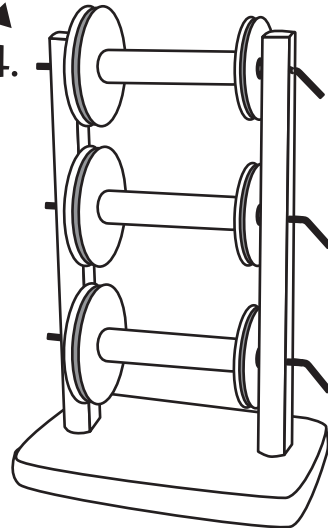

2

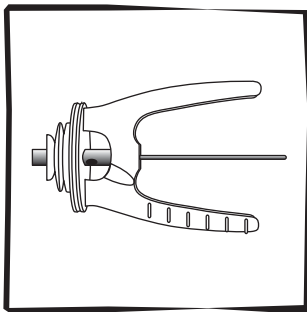

X12

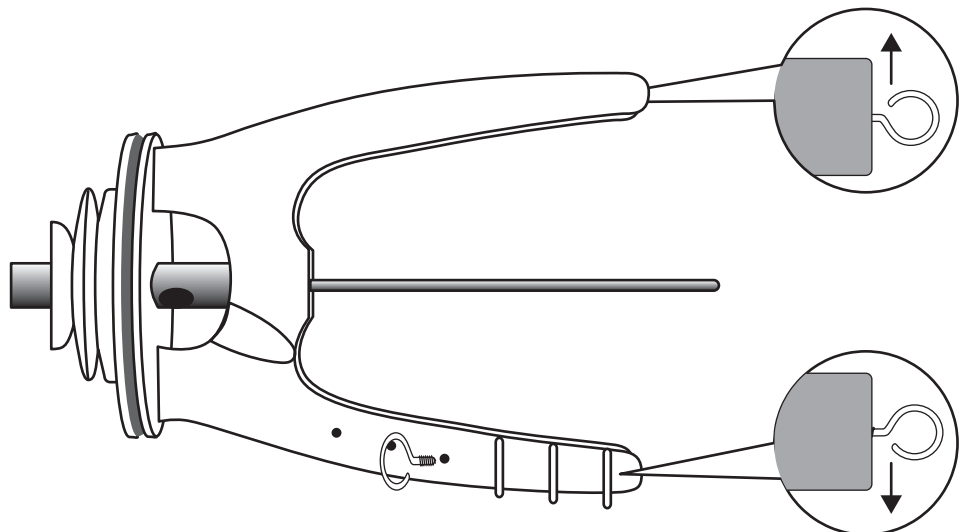

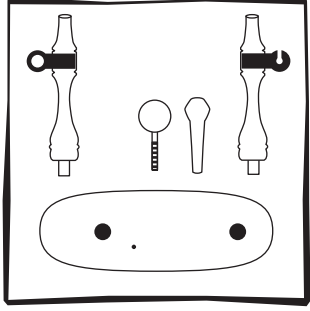
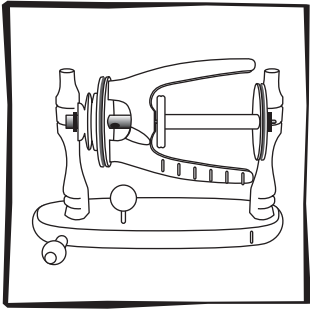

3

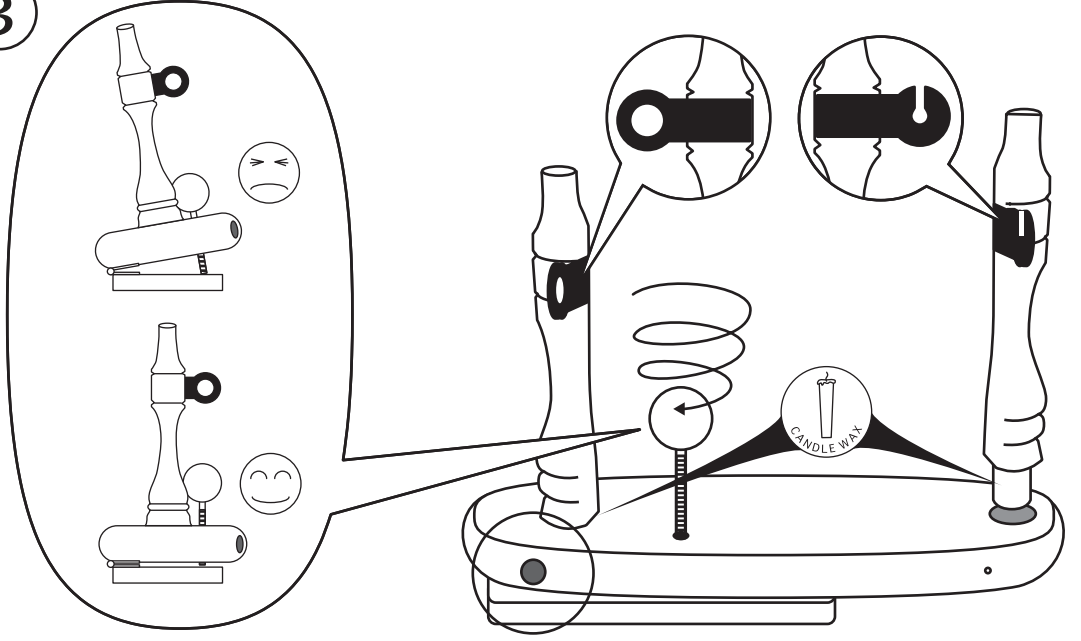

4

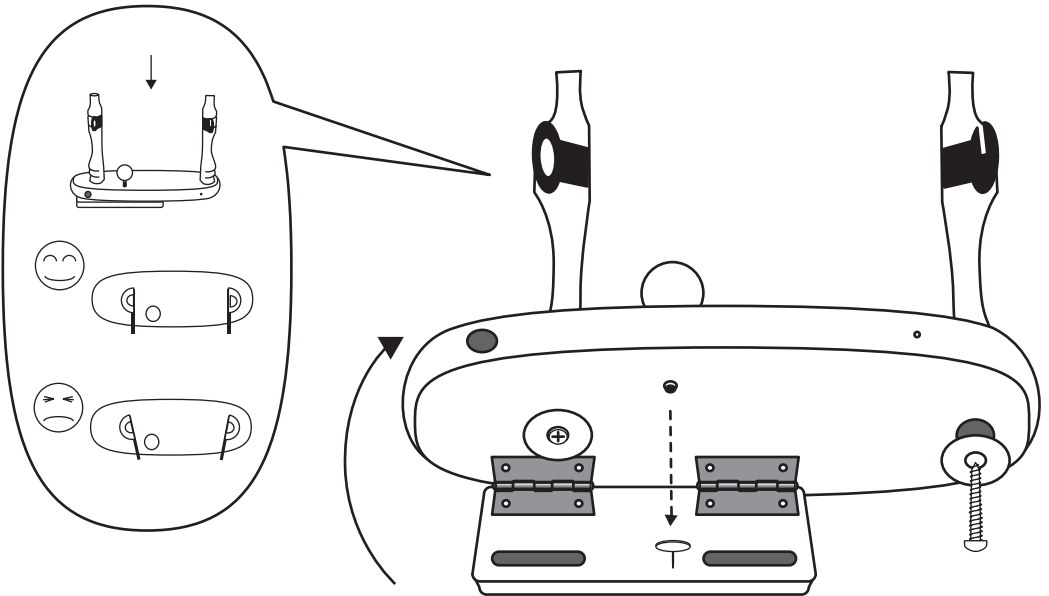
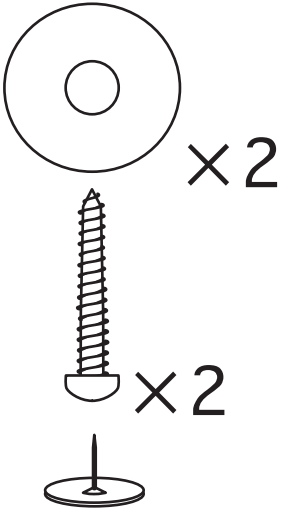

5

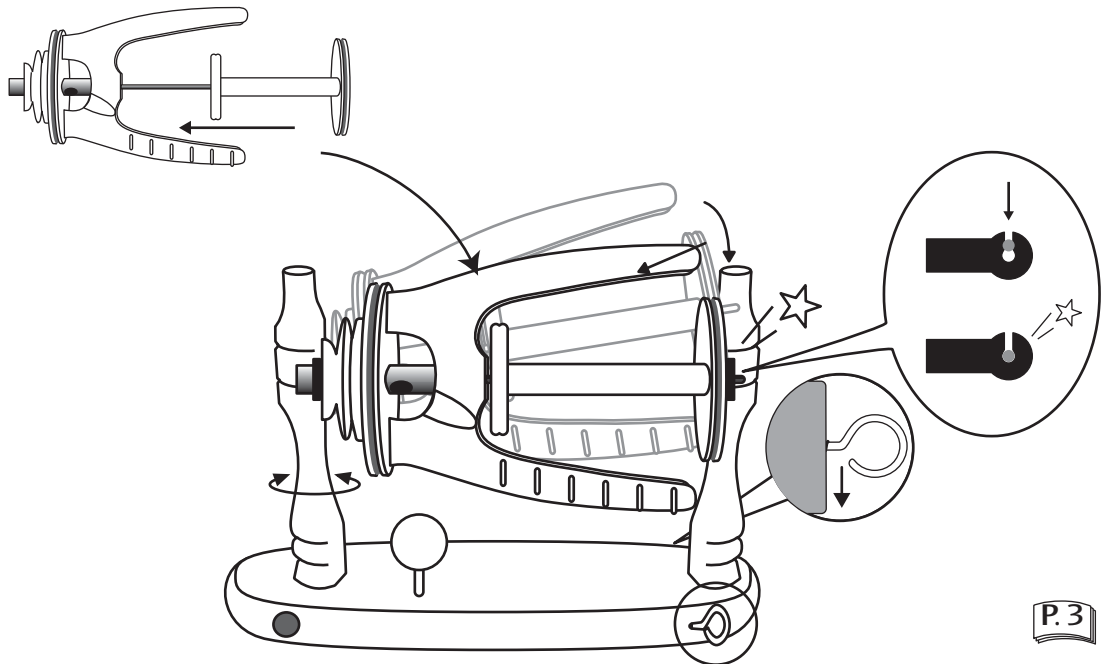

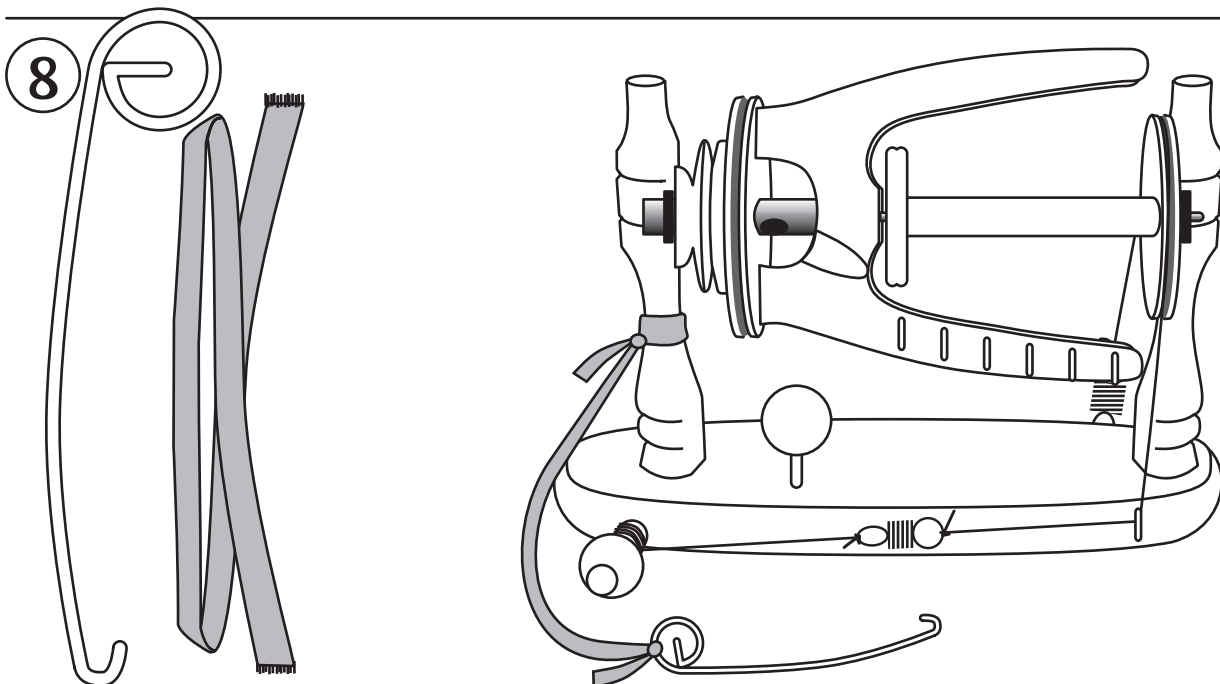
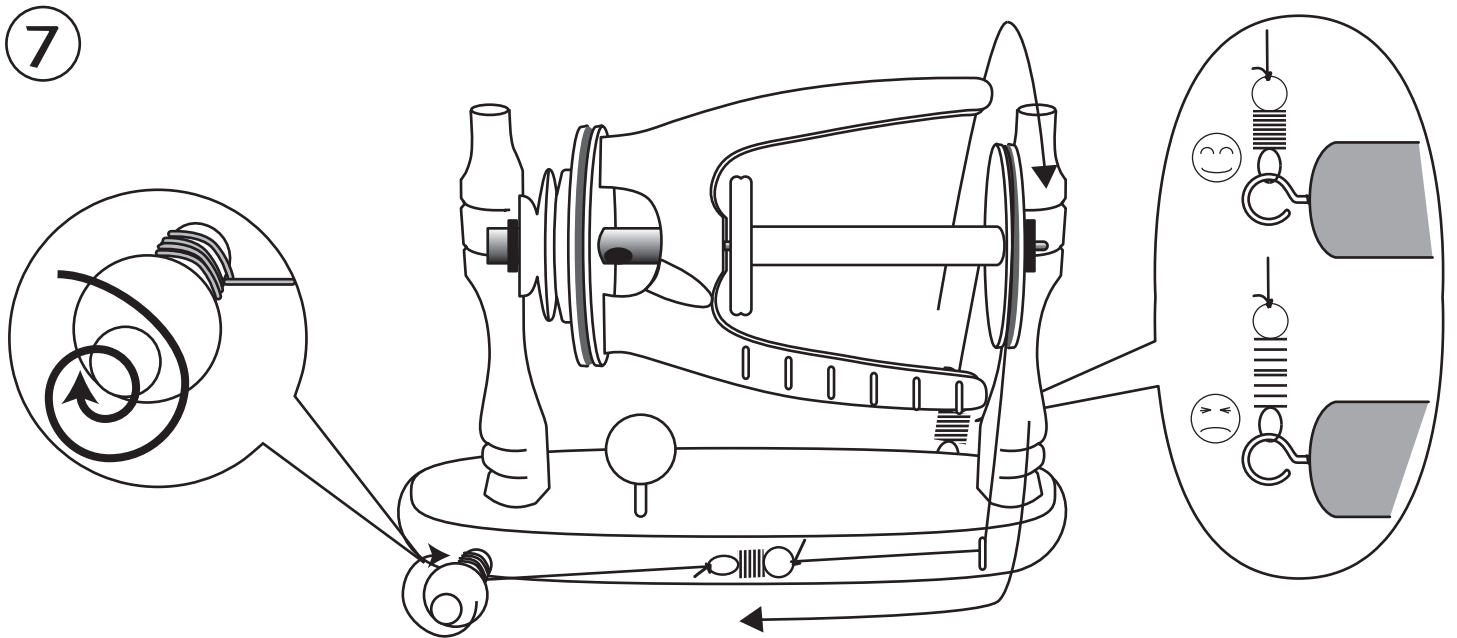
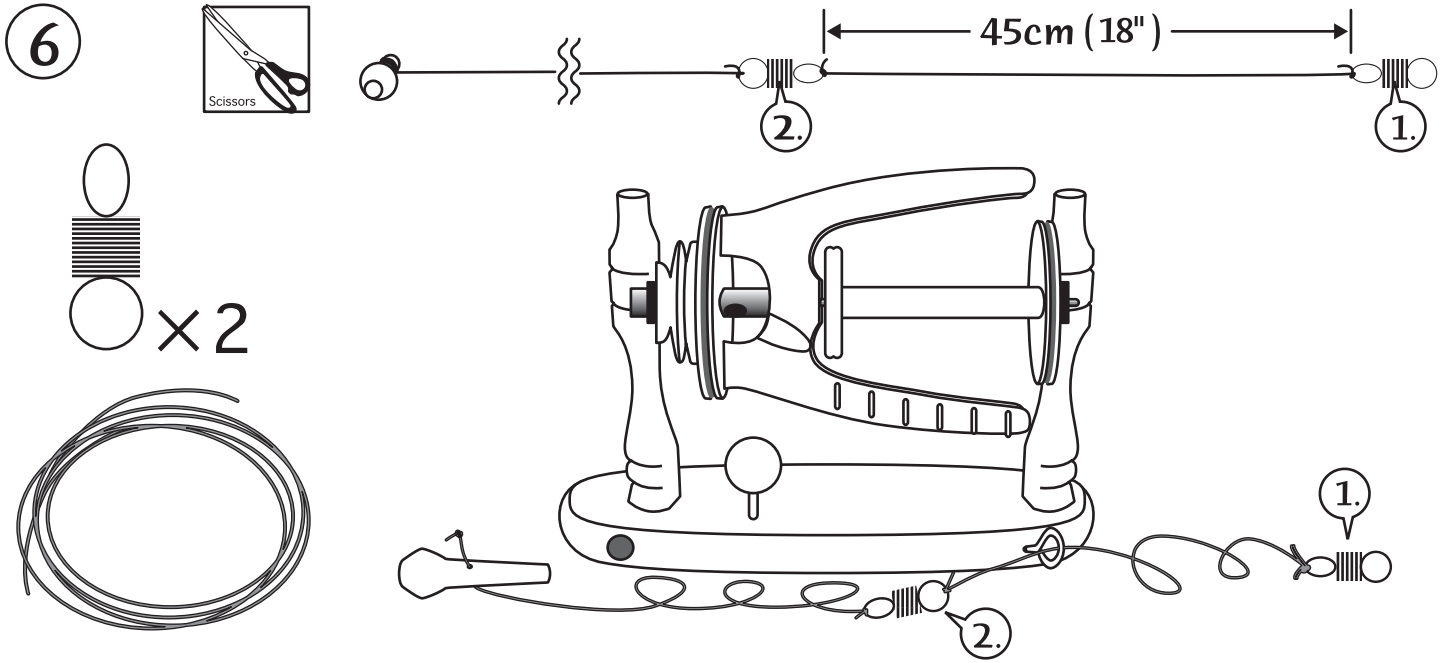

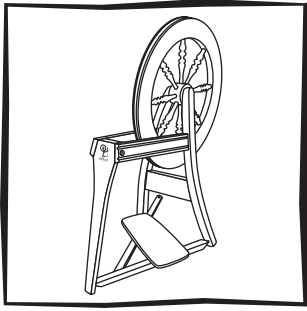

9

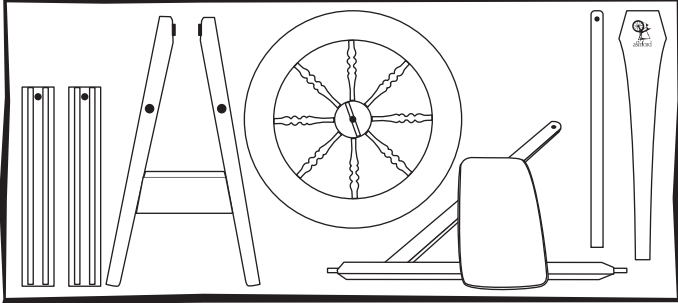
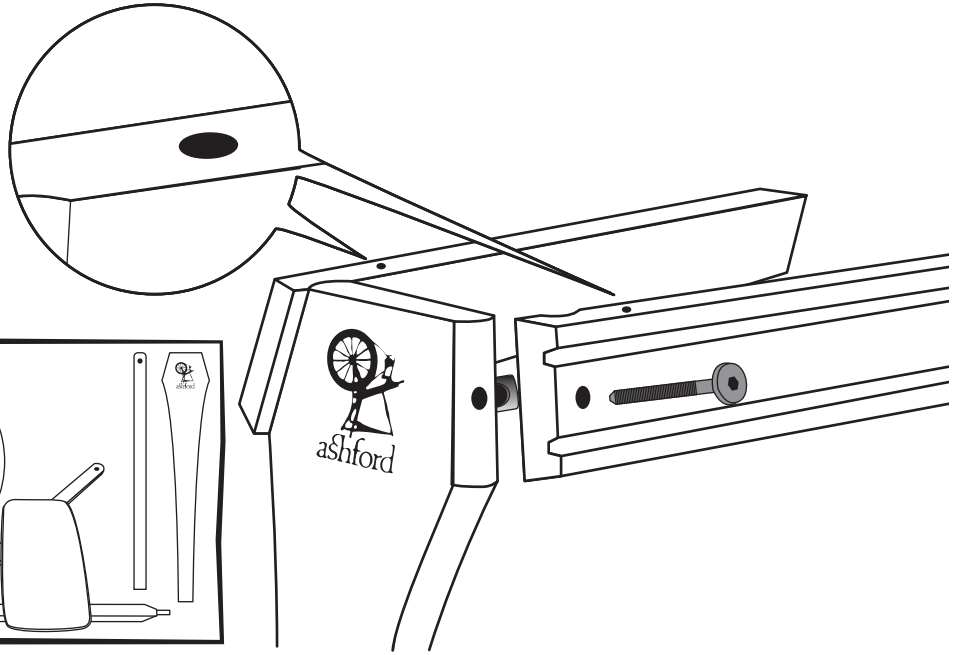

10 Allen Key

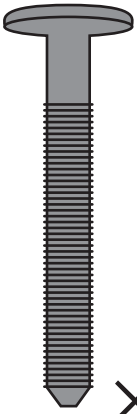

X2



X2

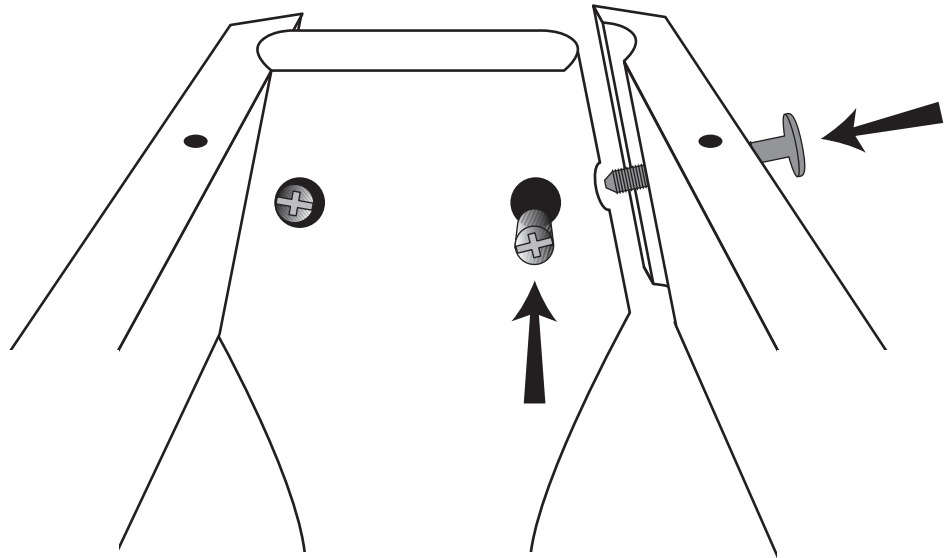

11

!Check

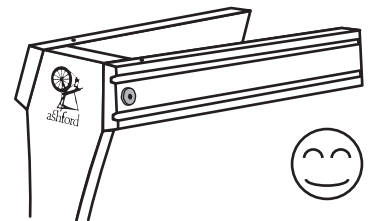
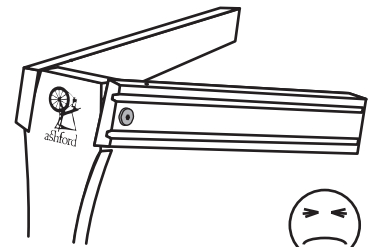
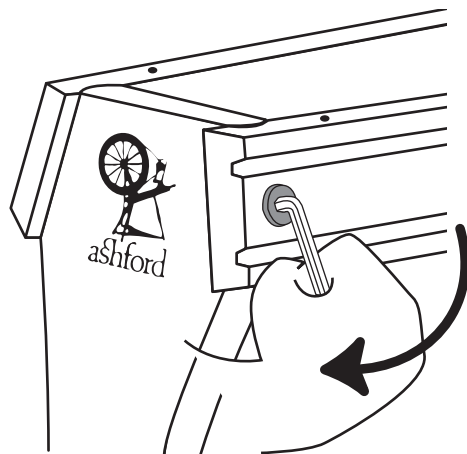

12

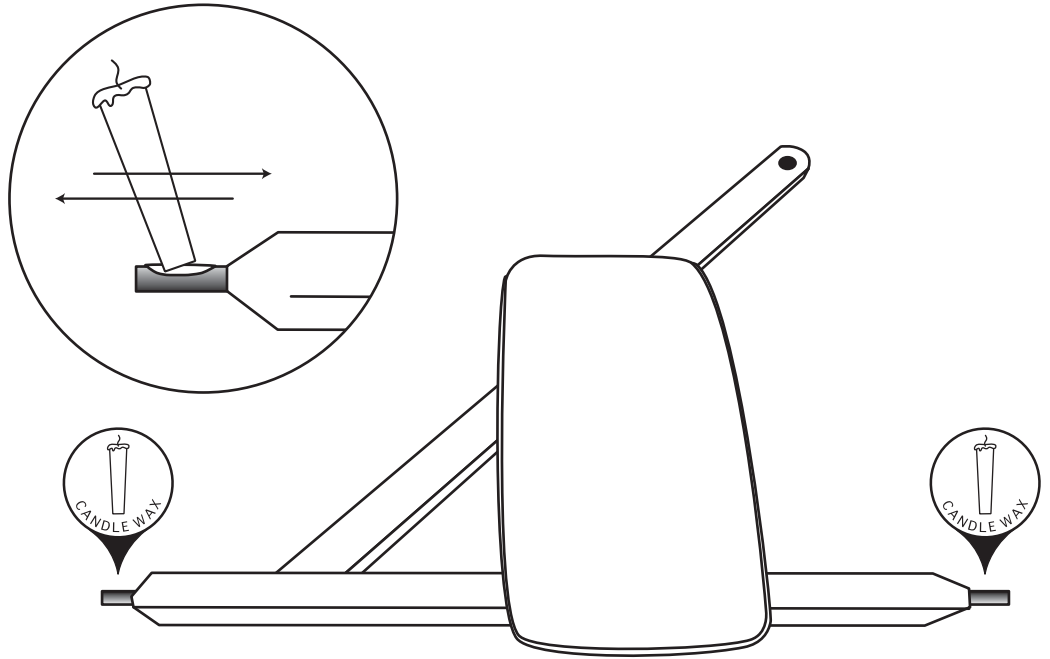

13

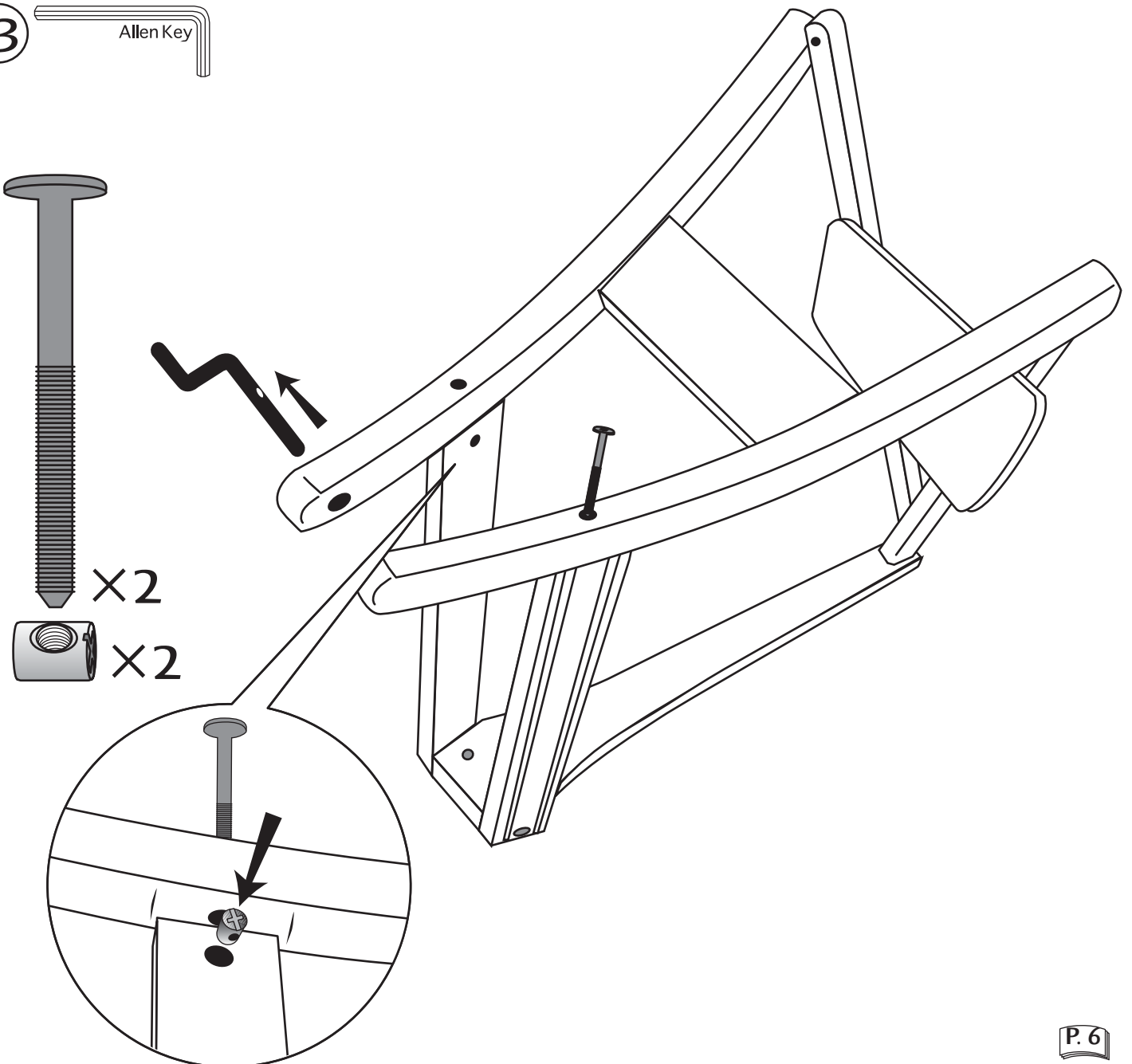

14

!Check

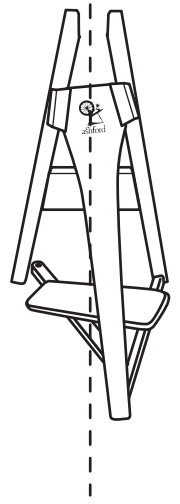
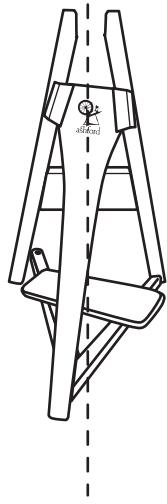

15

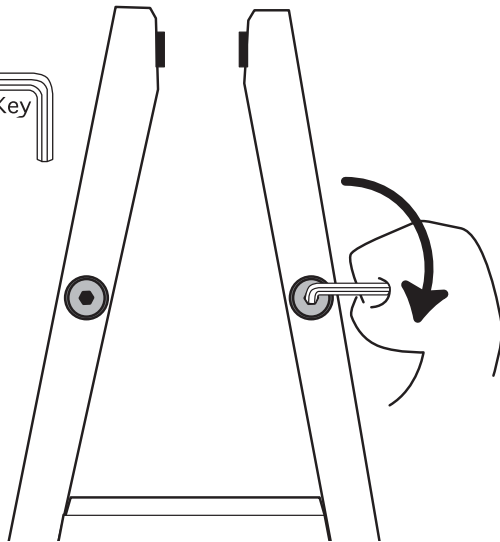

16

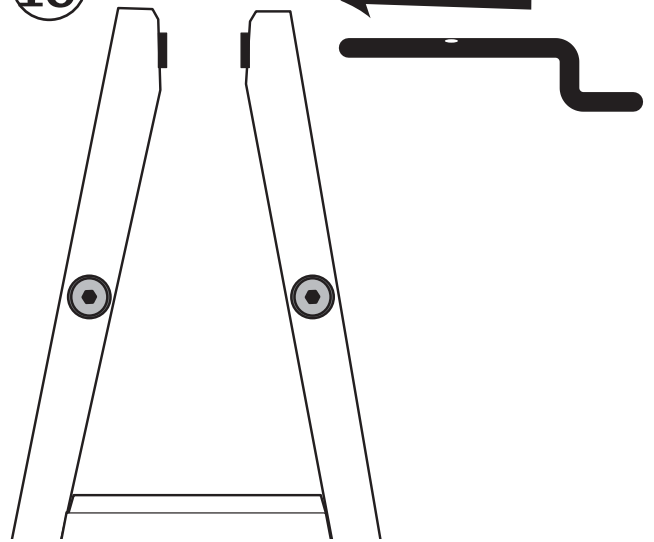

17

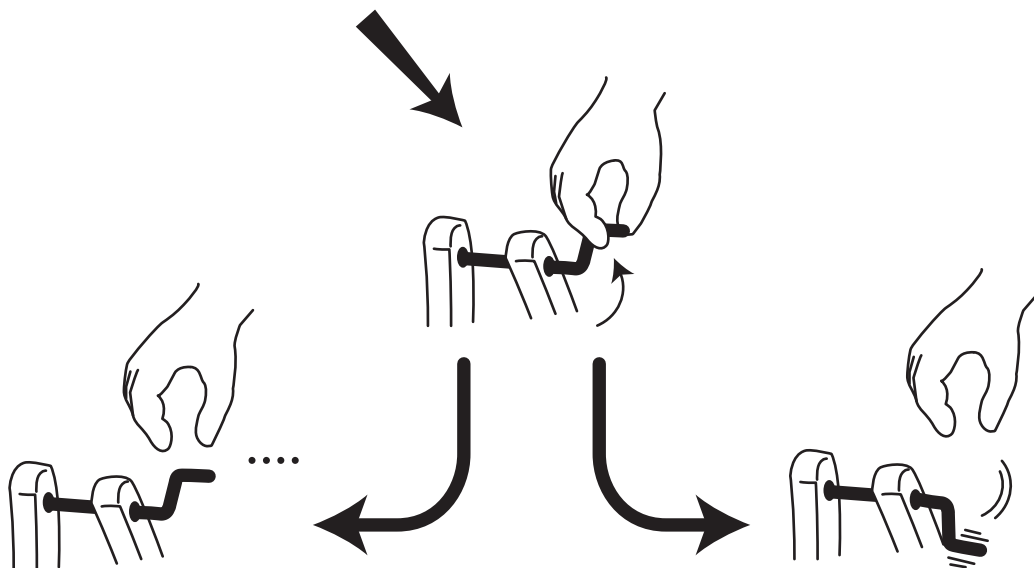

18

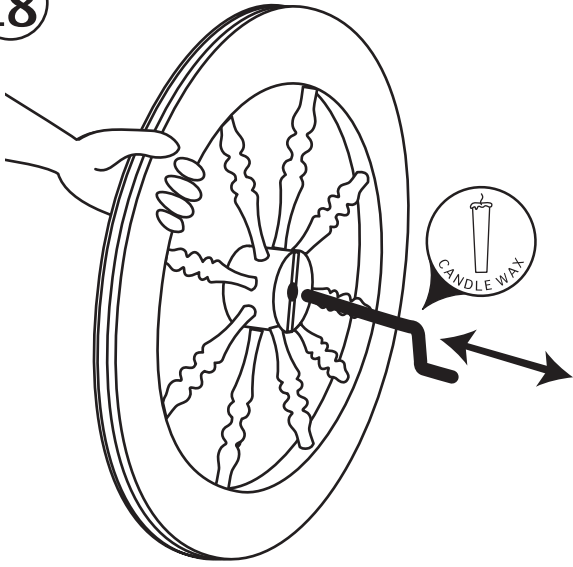

19

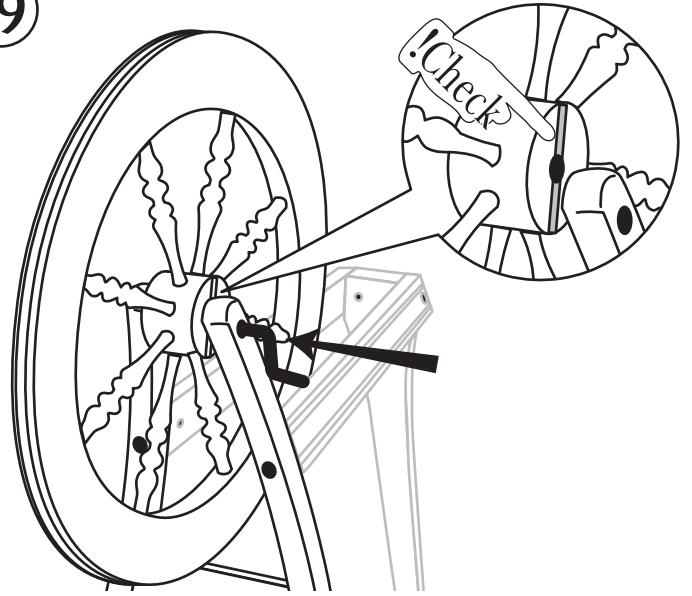

20

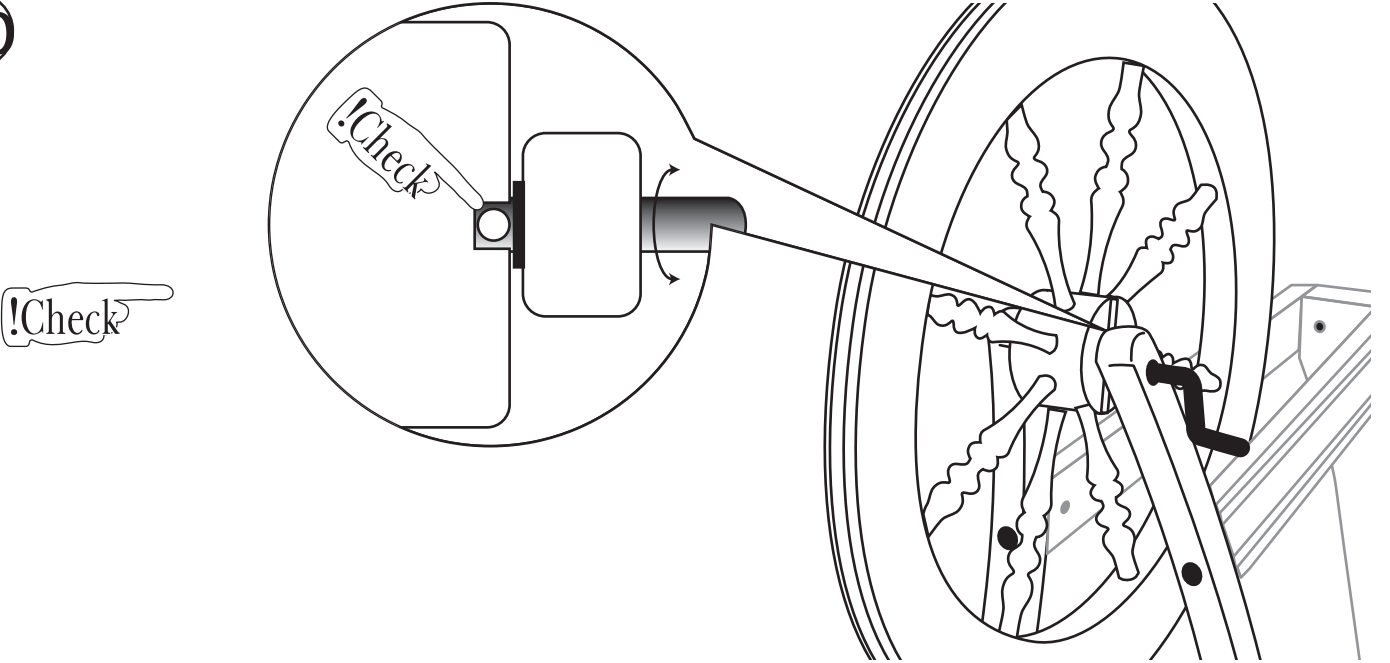

21

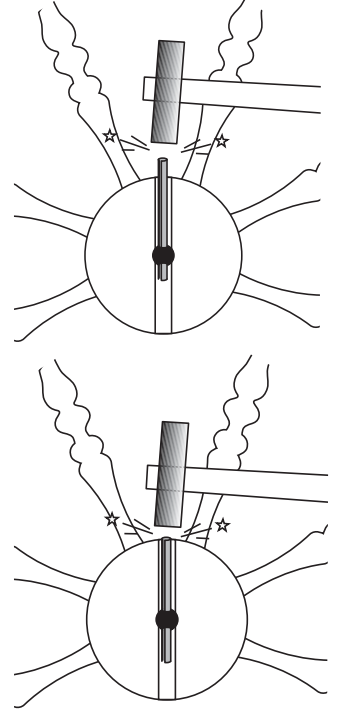
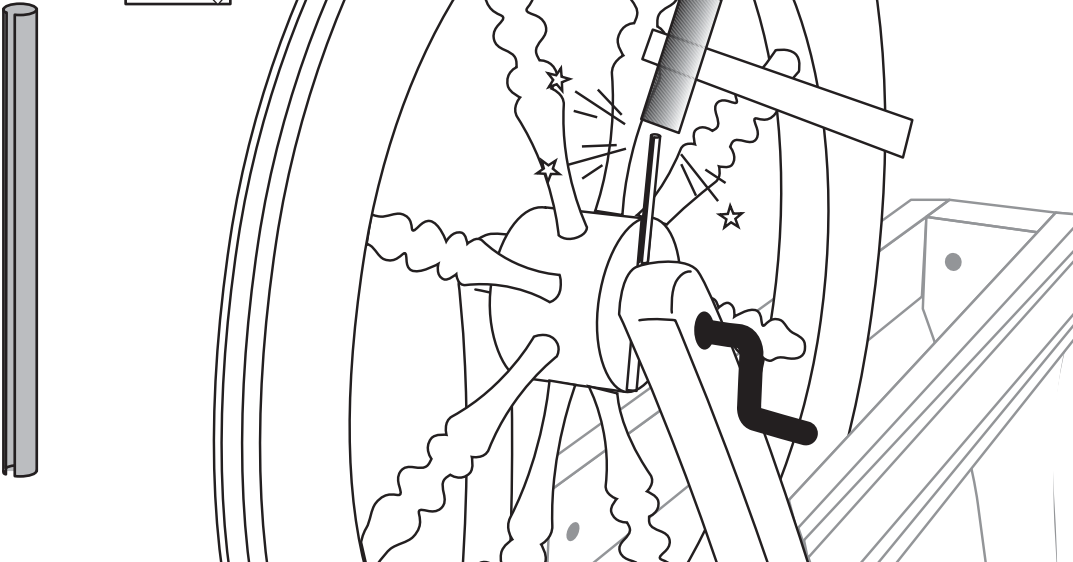
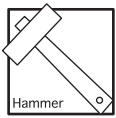

22

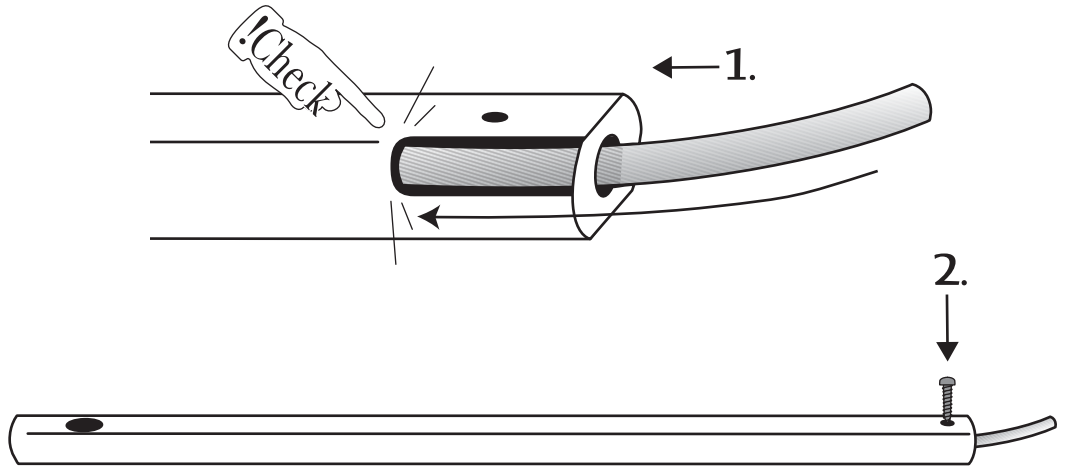
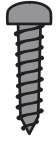

23

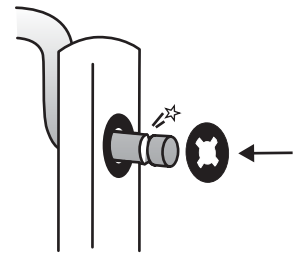
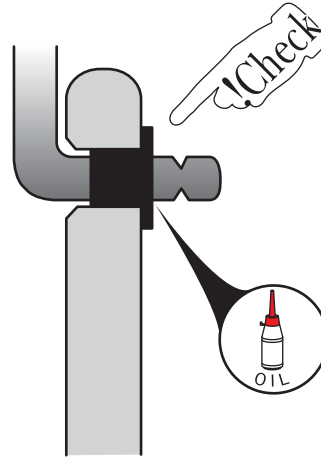
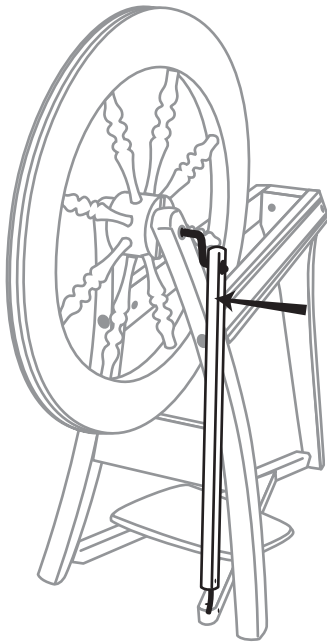

24

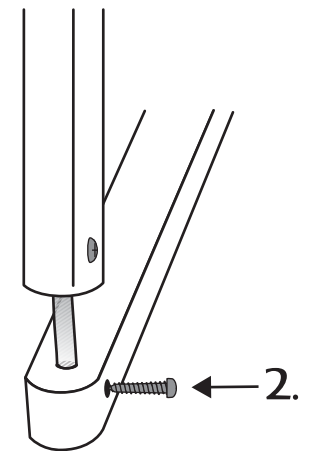
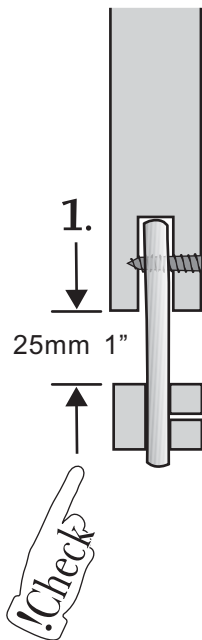
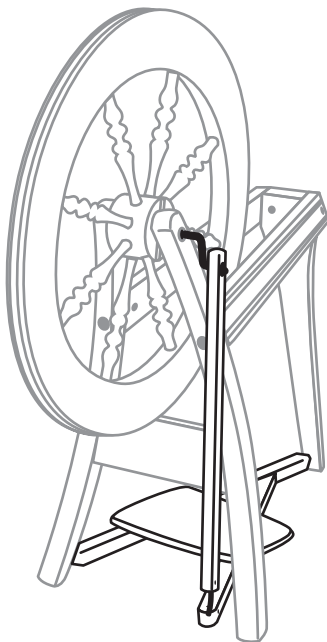
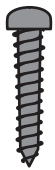

25

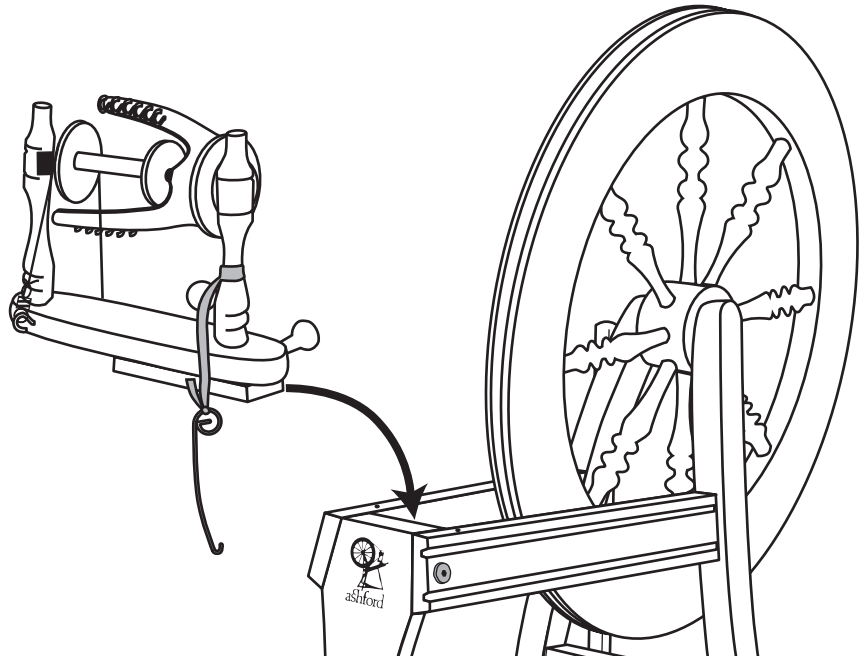
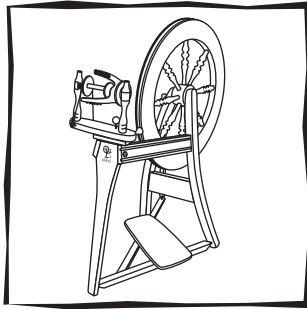

26



x2

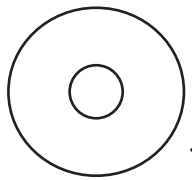

x2

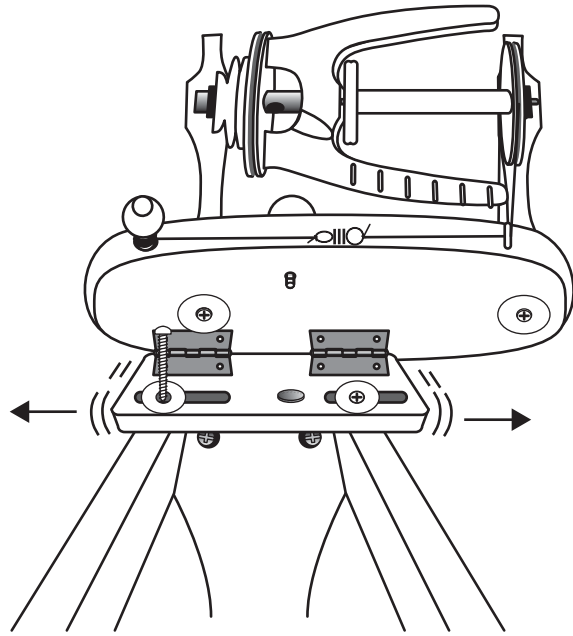

(3)

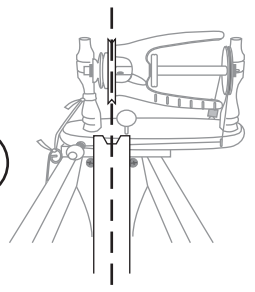

(2)

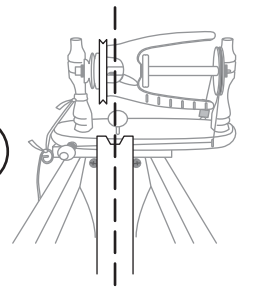

27

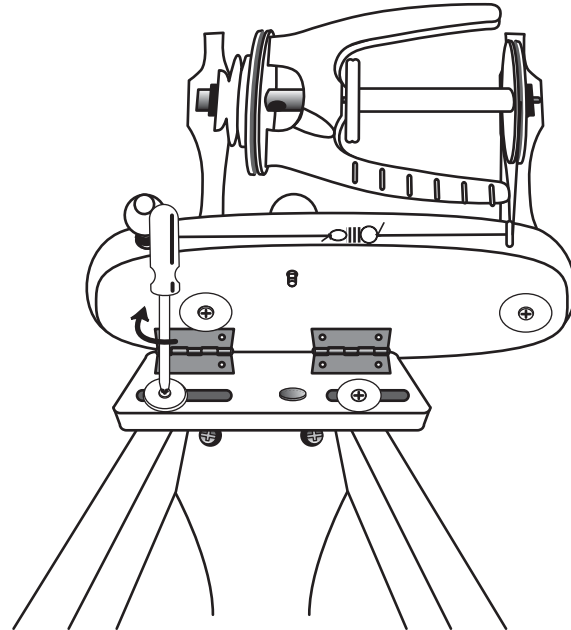

NOTE

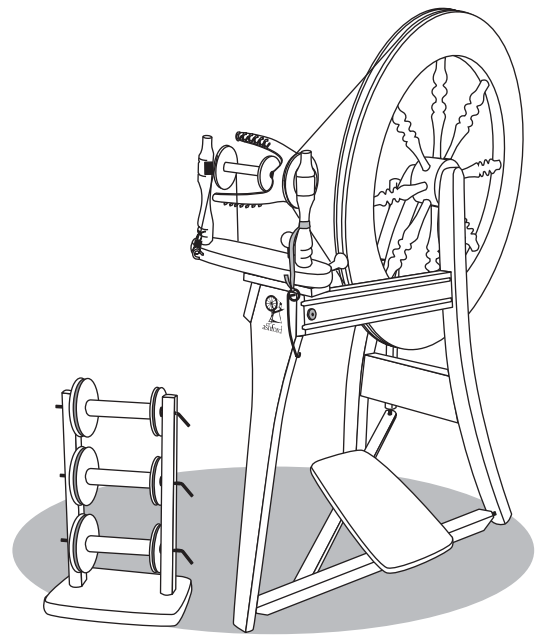
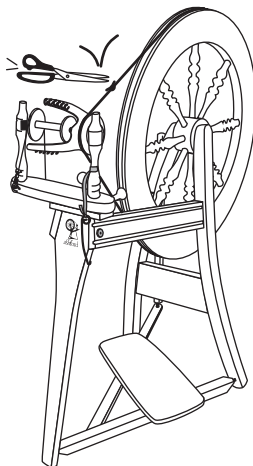
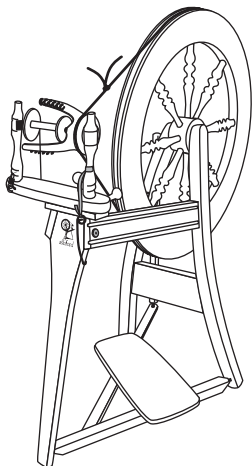
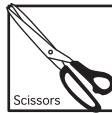
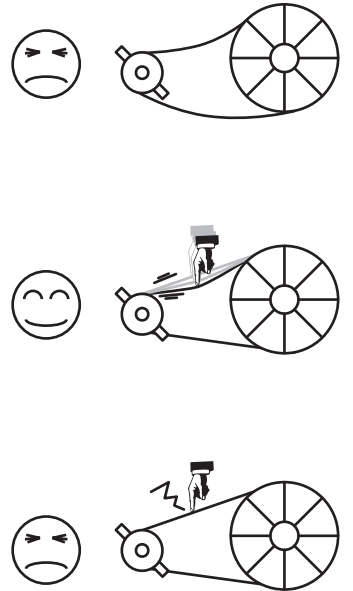
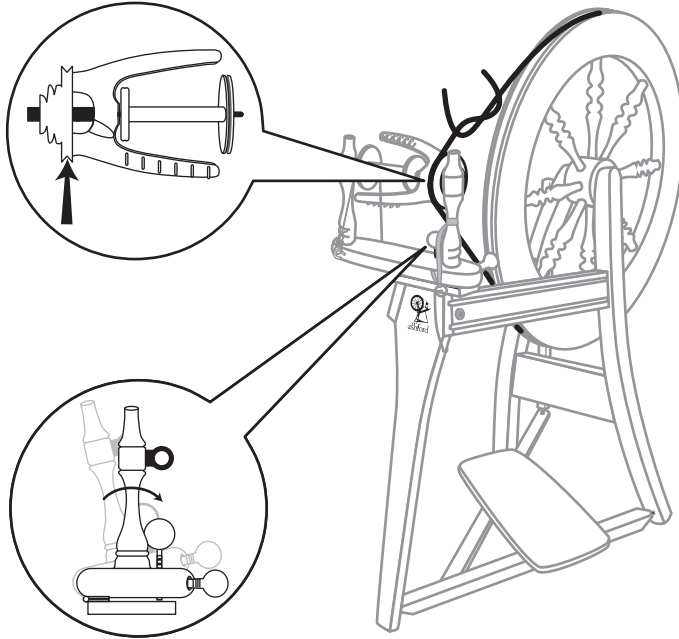
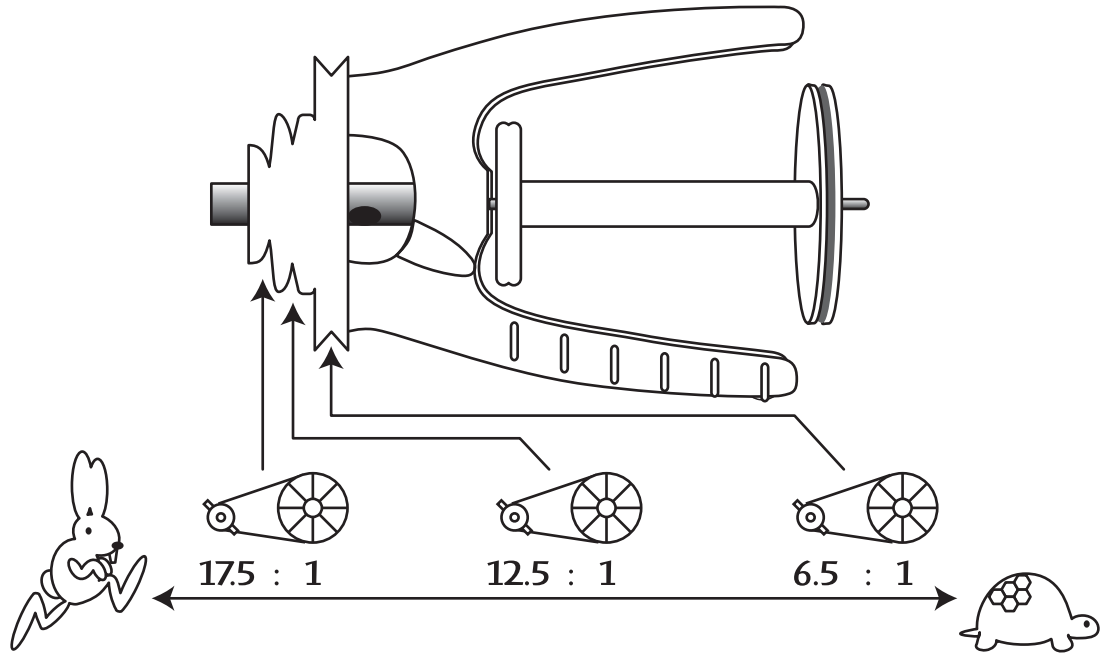



Does not pull yarn in

Brake band tension is too loose.

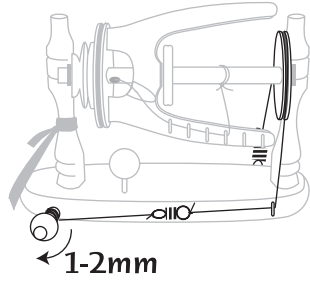

Or →

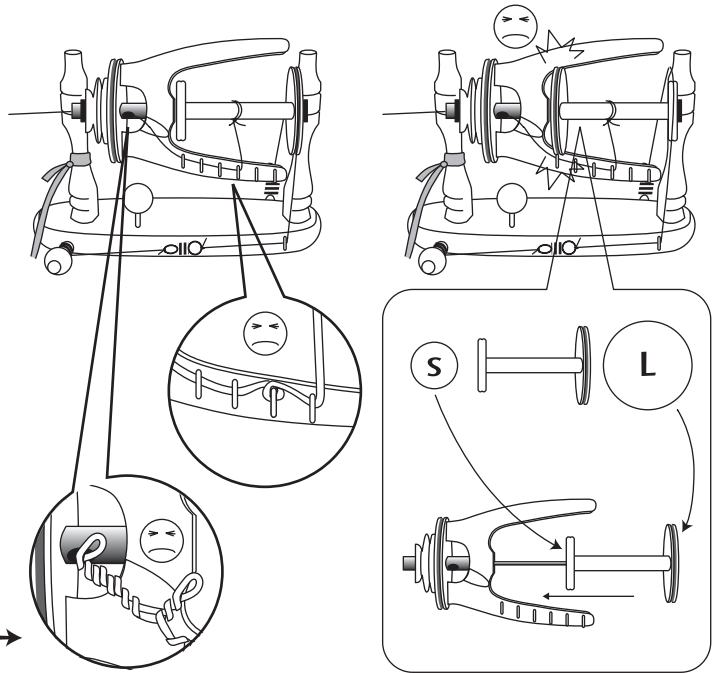

Yarn breaks

Brake band tension is too tight.

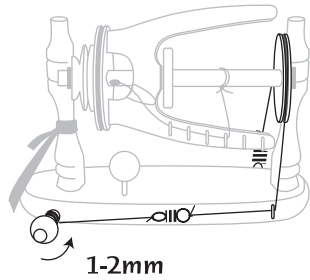

Or →

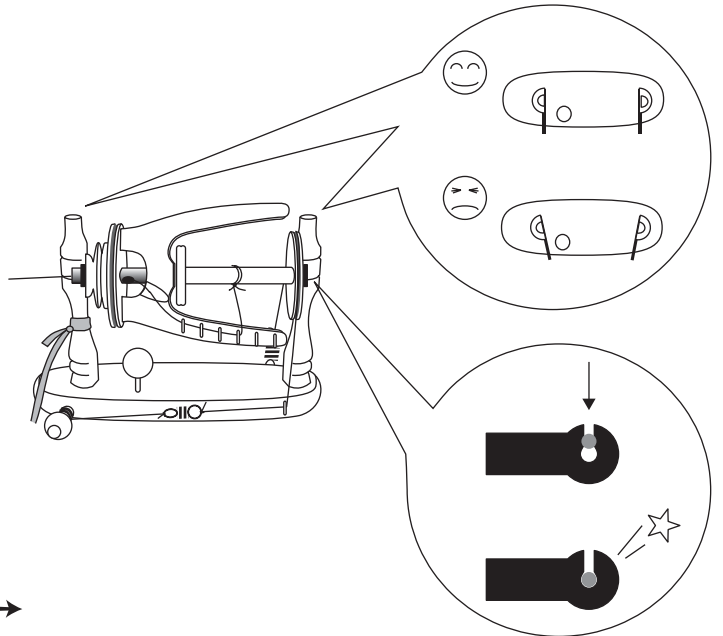

Hard to Treadle

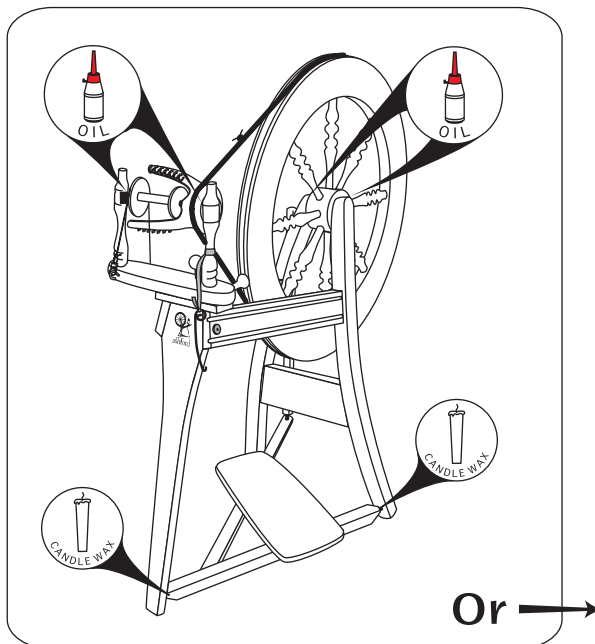

Or →

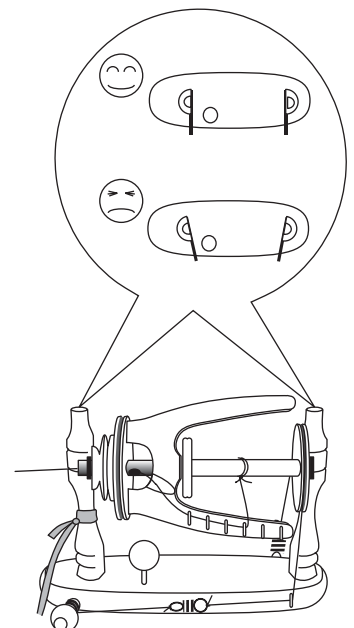

Drive band falls off easily

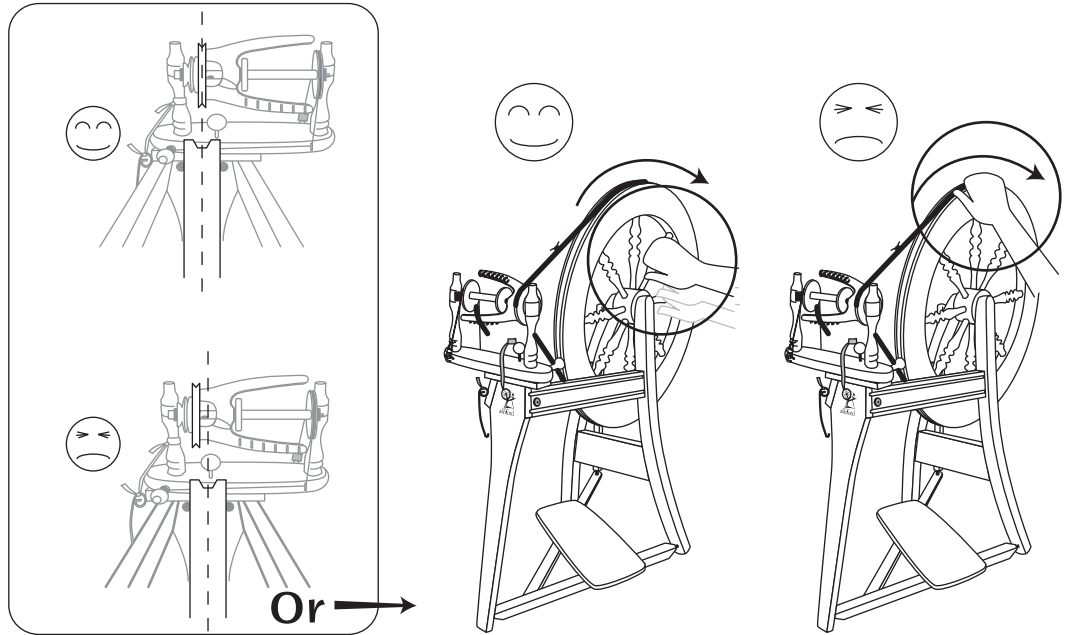

Strange sounds

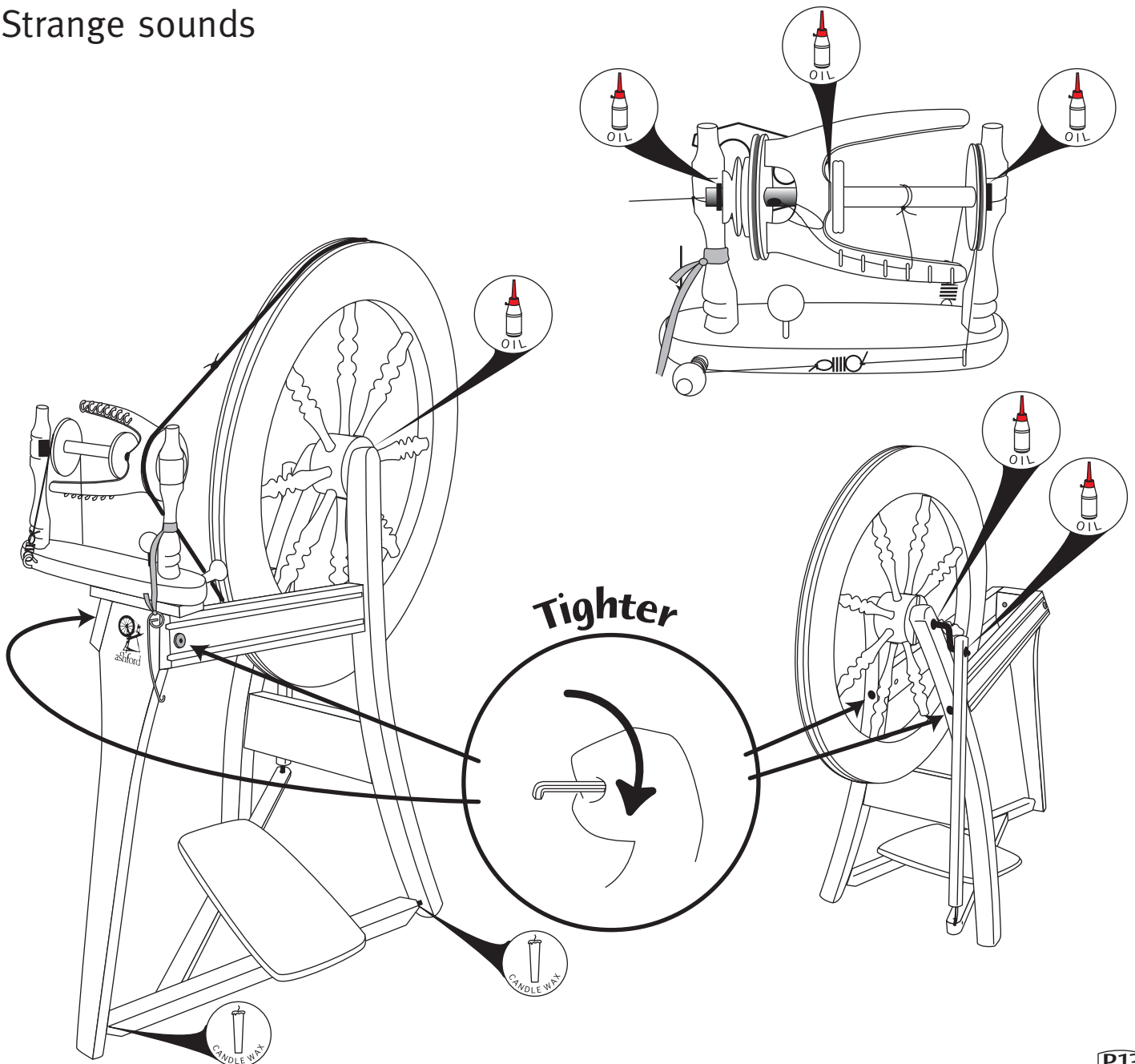

Traditional Single Drive Spinning Wheel - Hardware List

1 x Single Drive Band
1 x Nylon Brake Band

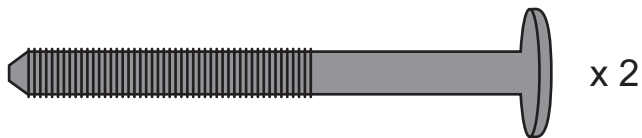

1 x Hub Pin



1 x Flexible Conrod Joint



1 x Drawing Pin

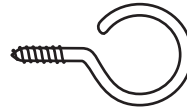

13 x Cup Hooks



1 x Screw Eye



2 x Tension Springs



1 x "O" Clip

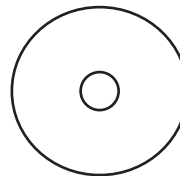

4 x Metal Washer



x 4

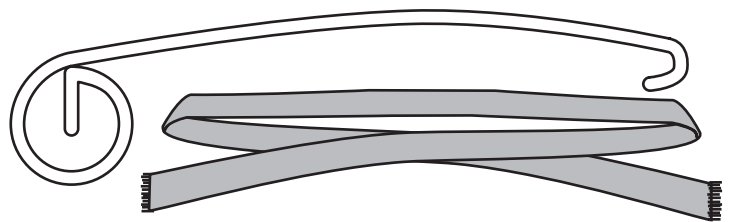

Threader Hook & Tape



1 x 4mm Allen Key

Traditional Single Drive Spinning Wheel - Parts List

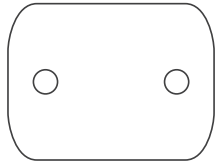

Lazy Kate Base

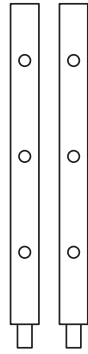

Lazy Kate Uprights

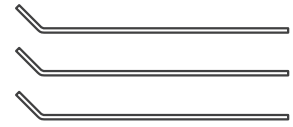

Lazy Kate Wires

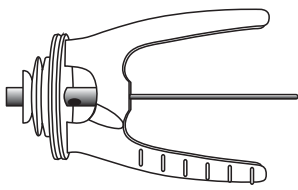

Flyer

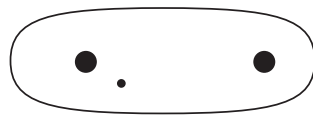

Maiden Bar

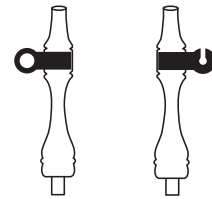

Maid Uprights



Adjusting Knob



Tension Knob



Single Leg



Side Rails

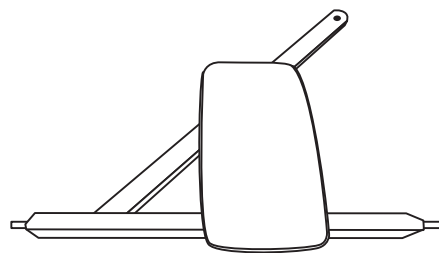

Treadle Assembly

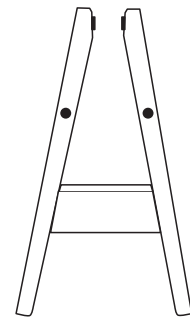

Wheel Support



Conrod

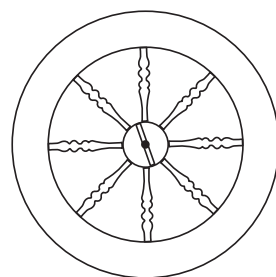

Wheel

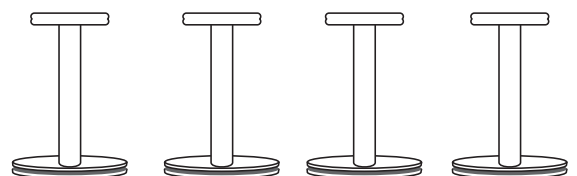

Bobbins

Meaning of Symbols

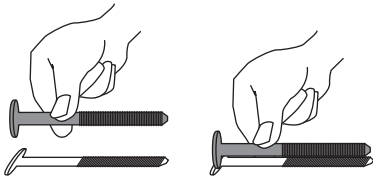

Check hardware against full size illustration.

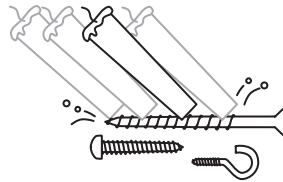

To make assembly easier use candle wax on the screws and hooks.



Check the directions carefully.



Right



Wrong

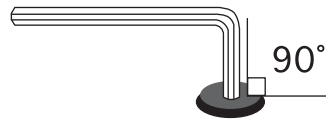

When you use the allen key, make sure it is at 90 degrees and is at the bottom of the hole

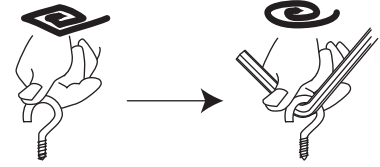

If the hook is hard to turn use the allen key.

Assembly Instructions for The Ashford Traditional Spinning Wheel - Single Drive -

Before Commencing - Read the instructions completely, identify the parts and note the assembly sequence.

Finishing the Wood - We recommend that the wood surfaces be waxed before assembly. This protects the kiln dried wood from climatic changes and enhances the beauty of the wood. For the Ultimate Finish - Use the special, natural, new formula Ashford Wax Finish. The Silver Beech Tree is a native of New Zealand and has a lovely variety of colour and grain. The Ashford Wax Finish will enhance the natural colours and beauty of the wood. Ashford Spinning Wheels are also available factory finished in clear lacquer or walnut finish.

- 1 Assemble the Lazy Kate. Note - the holes with countersunk holes on each upright face inwards.
- 2 Thread 12 hooks into the flyer.
- 3 Assemble the flyer unit. Check the shape of the nylon bearing on each maid upright, wax the dowel ends, then insert into the correct hole. Insert the drive belt adjusting knob into the maiden bar, turn until the end just protrudes.
- 4 Check the angle of the nylon bearings. Then secure the maid uprights with screws and washers. Do not overtighten. The maid uprights may be twisted to remove the bobbin. Position the drawing pin directly beneath the drive band adjusting knob.
- 5 Place a bobbin on the flyer and locate the flyer into the bearings. Thread the screw eye into the side of the maiden bar, and screw hook into the opposite side.
- 6 Attach the brake band. Thread it through the screw eye and then tie the springs as illustrated.
- 7 Put the brake band over the grooved end of the bobbin. Do not over stretch the springs.
- 8 Tie the threading hook to the front maid upright with tape.
- 9 Check the small hole is on the top of the side rails.
- 10 Then secure them to the single leg with bolts and barrel nuts.
- 11 Check the angle of the side rails and tighten.
- 12 Wax the steel rods in the treadle rail.
- 13 Loosely attach the wheel support to the side rails with bolts and barrel nuts. Then locate the treadle rail into the holes in the legs.
- 14 Check the angle of the single leg.
- 15 Tighten every bolt extra firmly with the allen key.
- 16 Insert the crank shaft into the wheel support.
- 17 The crank shaft bearings are self aligning. To check the alignment is correct, lift the end of the crank up and let go. If it rotates freely it's perfect.
- 18 Before placing the wheel in position, wax and insert the crank shaft then remove.
- 19-20 Align the wheel and hole in the crank shaft with the groove in the hub.
- 21 Tap the hub pin through the hub and crank.
- 22 The small piece of nylon rod forms a flexible joint at the bottom of the connecting rod. Secure with a screw.
- 23 Add a drop of oil to the connecting rod bearing. Fit the connecting rod to the crank shaft keeping the bearing to the outside. Push the O-clip onto the groove.
- 24 Insert the other end of the nylon rod through the treadle rail, leaving a 25mm gap between the con rod end and the treadle rail. Then secure with a screw.
- 25 Attach the flyer unit to the body with 2 screws and washers. These will be tightened shortly.
- 26 Move the flyer unit until the wheel and large flyer pulley are aligned.
- 27 Tighten the screws.
- 28 Ratios. Later you may find it easier to spin a finer yarn if your flyer rotates faster. To change ratio simply move the drive belt to the smaller flyer pulley. Check the alignment (step 25) and retension the drive belt.
- 29 Check the end of the adjusting knob is not protruding beneath the maiden bar. Then place the drive belt around the wheel and large flyer pulley.
- 30 Tie drive belt and cut off the extra.

各マークの意味

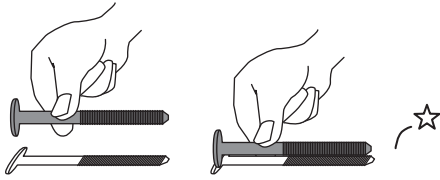

説明書表示のねじ類は全て実物大です。
実際にあわせて確認して下さい。

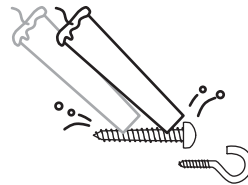

ねじ類にろうを塗っておくと
楽にねじが回せます。

!Check

その部品の形や、
向きに注意して下さい。



良い



だめ

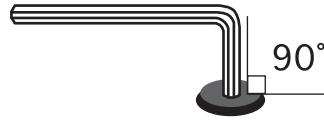

六角レンチは直角にしてください。

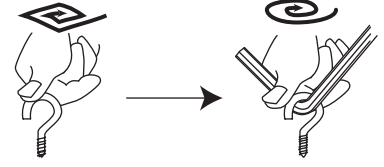

レンチを使うと回しやすくなります。

アシュフォード・トラベラー ダブルドライブの組み立て方

(組み立て説明書の図を見ながらお読み下さい)

◎組み立てる前に、この説明書の図と実際の部品の形を照らし合わせておくと、より簡単に組み立てることができます。

◎気候の変化や乾燥から木材を守り、良い状態を長く維持するために組立前の塗装をお勧めします。塗装には是非、アシュフォードのワックスキットをお使い下さい。布ですりこむだけでもとの美しい木肌を隠さず、きれいに仕上がります。むらにもなりません。

- 1 フライヤーの表と裏にフックをねじ込みます。
- 2 蝶番をフライヤーの台の上に取り付けます。
- 3 方向に注意して、フライヤー支柱を差し込みます。ドライブベルトの張りを調節するテンションノブを取り付け、先が下から出っ張らない程度まで回します。
- 4 支柱の黒いナイロン軸受けがお互いに平行になるよう調節し、台の裏からねじで止めます。支柱を握り、力を入れて回るくらい少しゆるめに止めておくとフライヤーの取り外しが楽です。
輪型の金具を台にねじ込みます。
- 5 フライヤーにボビンを入れ、フライヤーの台に取り付けます。ボビンの方向に注意して下さい。フックをフライヤーの台の上面にねじ込みます。
- 6 ブレーキバンドを取り付けます。スプリングをブレーキバンドに結び前に、輪型の金具を通すことを忘れないようにしましょう。
- 7 ダブルドライブで使うときは、ブレーキバンドは使いません。ブレーキスプリングがのびない程度の張りにして、図のようによけてかけておきます。
- 8 ペダルを組み立てます。
- 9 全てのねじが棒の真中になるところが正しい位置です。
- 10 本体に足を付けます。足の前後に注意して下さい。図中「!」印の穴を左側にして置いた場合、向こう側にペダルを付ける足（穴があいている）が入ります。
- 11 8、9で組み立てたペダルの両脇の金属の部分にろうを塗り、足の穴に差し込み、本体に差し込みます。
- 12 ペダルの入っている穴がずれてしまわないように注意しながら、交互に少しずつ打ち込んでゆきます。
- 13 後ろ足を打ち込みます。穴の最後までキチッと打ち込んで下さい。
- 14 それぞれの足をねじで止めます。
- 15 表を向けます。
- 16 はずみ車の支柱の違いを確かめます。
- 17 穴の突き抜けていない支柱を手前（ペダルが取り付け

てある足側)、突き抜けている方を奥にして仮止めします。お互いのナイロンベアリングが向かい合うようにします。

- 18 穴がお互いに真正面を向くようにします。
- 19 位置が決まったら、17で仮止めしたボルトをしっかりと締めます。六角レンチを使うときは、ねじの穴に垂直に、奥まで差し込んで回しましょう。ねじ山が壊れてしまうと回らなくなってしまうので大変です。
- 20 さらに微調節をします。図のようにナイロンベアリングの穴の向きを微調節して、はずみ車の軸（クランク）が一番楽に回る位置を見つけて下さい。クランクを上の方で指を放し、楽に下がるくらいが理想的です。
- 21 はずみ車を取り付けます。
- 22 切れ目からクランクにあいた穴を見つけます。
- 23 ハブピンをたたき込みます。
- 24 コンロッドジョイントをコンロッドに取り付けます。
- 25 クランクシャフトの先にコンロッドを取り付け、留め金で止めます。
- 26 コンロッドにペダルを取り付けます。
- 27 フライヤーの台が乗る支柱を取り付けます。筒型ナットが入る穴を内側にします。
- 28 ボルトをしっかりと締めます。
- 29 フライヤーの下台を差し込み、ねじで止めます。
- 30 フライヤー台の裏に取り付けた蝶番とフライヤーの下台を、まず仮止めし、はずみ車の位置が、フライヤーの溝とボビンの溝の真ん中に一直線になるように調節してからねじを締めます。
- 31 回転する部分にほんの少しの油を付けます。引き出しフックを使いやすい場所に結びます。
- 32 回転比は、ドライブベルトをかける場所によって変えることができます。ベルトをかけ替えるときはフライヤーの台の位置も調節して下さい。14：1の回転比は、フライヤーにブレーキをかけ、ボビンにドライブベルトをかけると得られます。
- 33 フライヤーの台が傾いていないのを確認して、ドライブベルトを取り付けます。図のように、1周目はフライヤーに、2周目はボビンにかけます。張りに注意して下さい。きついと引きが強く、弱いとあまり引きません。ドライブベルトの張りは、紡ぎながら様子を見てテンションノブを使って調節します。
- 35 ボビン立てになる鉄棒を金槌で打ち込みます。

注 しばらく使っていて、回りが悪くなってきたり、変な音がし始めたら油の差し時です。ペダルの両側は、シミにならないようにロウを使って下さい。
本製品は天然木製品ですので、時の流れや、気候などの条件で木の状態が変わってきます。ボルトを締め直すときのために、付属の六角レンチはなくさないようにしておいて下さい。

How do I make my wheel easy to treadle?

The most important aspect of spinning wheel maintenance is to ensure the 3 main elements of the spinning wheel, ie the wheel, the flyer and the bobbin, are free to rotate. Check this by firstly removing the drive & brake band. Use Ashford spinning wheel oil, 30 grade motor oil or vaseline where recommended.

1. Wheel.

Spin the wheel. It should rotate freely for around 60 revolutions.

- Wheel bearings. Prise the wheel supports apart and apply a drop of oil onto the crank between the hub and the bearings.
- Con rod bearing. Oil & check to ensure it isn't pinching.
- Treadle pins. Use either candle wax or oil to reduce noise and friction.
- Hinge pins on double treadle wheels. Oil as necessary.
- Check there is approx. 1/16" (1.5mm) side play between the hub & bearings. If the wheel appears to be pinched between the wheel supports loosen the bolts or screws holding the frame, spin the wheel until it is free & then gradually retighten the bolts or screws. On the Traveller this can be achieved by loosening the 2 bolts holding the wheel supports & moving them until correct.
- Check that the gap between the bottom of the con rod (pitman) and the treadle rail is approx 1/2" (10mm). If greater than this it can cause ankle strain & if closer the two can bind thus stretching the joint.

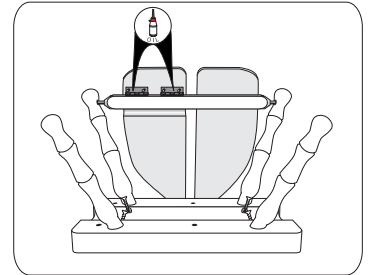
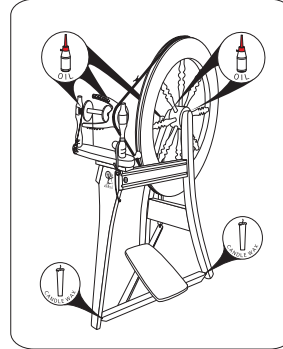

2. Flyer.

Spin the flyer. It should rotate freely.

- Oil the flyer bearings.
- Ensure the flyer bearings are at right angles to the flyer shaft. If not loosen the screws holding the maid upright & realign. Then retighten the screws.
- Check there is approx. 1/8" (2-3mm) end float between the flyer, bobbin & flyer bearings.
- Check the drive band is aligned with the wheel. If necessary, loosen the screws holding the maiden bar, realign & tighten.
- If the drive band is worn replace with a new Ashford drive cord or a medium soft cotton string.

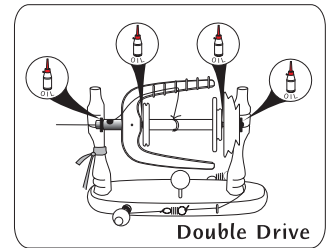
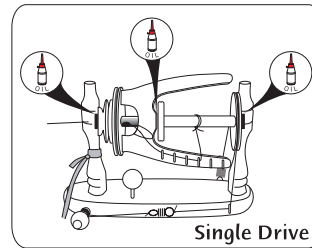

3. Bobbin.

- Check & oil the bobbin bearings.
- If the bobbin doesn't run freely the bearings may be too tight on the flyer shaft. If so ream them with a 1/4" (6.25mm) round fine chain saw file or fine sandpaper wrapped around a pencil.
- If your wheel has been factory finished, it may be necessary to scrape any lacquer off the spindle that may have been inadvertently applied.
- On double drive wheels the flyer whorls have "V" grooves. The bobbin whorl is "U" shaped. This difference enables the wheel to drive the flyer at a constant speed and allows the bobbin to accelerate or slow down when drafting. Check the bobbin whorl is smooth and "U" shaped.

What do I do if the yarn snags or won't draw in?

- Ensure the bobbin rotates freely on the flyer shaft. Clear the hole with a file & oil the bearings.
- Check the flyer hooks are smooth & are not snagging the yarn. Replace the hooks if necessary.
- Check the orifice is clean & free from snags. Clear with a file.

Single drive

- Check the brake band is over the bobbin whorl & the springs are just starting to extend.

Double drive

- Check the drive band is around the small whorl on the bobbin & the largest flyer whorl.
- Check there is sufficient tension on the drive band.

What do I do to prevent the yarn being jerked out of my hands?

Single drive

- Reduce the brake band tension until the springs are just starting to extend.
- Check the bobbin whorl is smooth. If necessary smooth with sandpaper.
- Apply a drop of oil to the bobbin whorl.

How much tension should I have on the drive band?

- Only have sufficient tension to drive the flyer & bobbin with-out slipping. Too much tension makes treadling harder.
- Generally the drive belt should be able to be easily depressed about 1" (25mm). Turn the belt tension knob until you have the correct tension.
- Apply belt rosin or fit a stretchy drive belt "Turbo Kit" to increase grip.
- If the drive belt has stretched, shorten and retie it.

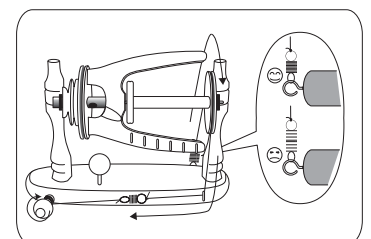

Why use two tension springs on the brake band?

Two springs fitted either side of the bobbin whorl will make plying easier as it allows the brake band to flex rather than pull against the tension knob. Spare springs are available from your Ashford dealer. Add an extra spring or replace if stretched.

What can I do to my Elizabeth wheel to keep it from getting out of alignment?

For easy treadling & to ensure the drive band remains in the whorls, check the alignment of the wheel with the flyer & bobbin whorls. If not aligned loosen the bolts securing the main wheel supports under the base with a 4mm allen key. Twist the supports slightly so the wheel moves to the left or right until correctly aligned. As you tighten the bolts, ensure that the wheel continues to turn freely.

How do I avoid my yarn getting over- twisted?

- Slow the flyer down by putting the drive band onto a larger whorl.
- Treadle slower. Around 60 RPM is a nice easy treadle speed.
- Draft your yarn faster. This may require you to better prepare your fibre prior to spinning.

How do I avoid my yarn breaking?

- Make your yarn stronger by treadling a little faster.
- Draft more fibres to make the yarn a little thicker.
- Pinch and slide your fingers along the spun yarn so you are always in contact with the yarn. This also prevents the 'twist' entering the undrafted fibres.

The spokes & hub on my wheel are very loose. How do I repair it?

It's a relatively simple repair job. Remove the crank, prise open the hub so it's in 2 pieces but make a mark so you can put the spokes back in the same holes. Use regular wood glue on the spokes and hub and glue it back together clamping it with 2 x G clamps. Leave the crank through the hub so the hole remains aligned but remove it and clean out the hole for the hub pin before the glue dries. Check that the rim and crank are at right angles so the wheel will run true. If unsuccessful a replacement wheel can be ordered from your local Ashford dealer.

The stretchy drive band has stretched a little. Can I rejoin it?

We recommend the drive bands always be loosened when not spinning. However if stretched, cut a short section out including the original joint and rejoin by melting the ends with a gas flame (a match is OK but tends to deposit carbon on the joint), then just push the ends together & hold while the material cools.

Any suggestions for spinning superfine merino?

To give a lighter draw-in, replace the brake band with a 4 ply commercial knitting cotton with a light rubber band on either side of the bobbin. Check the bobbin whorl is smooth & apply a drop of oil.

How do I prevent my spinning wheel walking away from me?

- Check the wheel is free running.
- Treadle with a down-wards action rather than away from you.
- Attaching rubber feet to the ends of the legs
- Spin with your wheel and chair on carpet or a rug

How can I tell if my Traditional Wheel will accept the double treadle conversion kit?

The double treadle will cover all Traditional Wheels made after 1972. These wheels have a 19 3/4" (50cm) long front treadle rail. Earlier models (pre 1972) were about 2" (5cm) longer.

What is the best finish for my spinning wheel?

Our spinning wheels are made from Southland Silver Beech, a beautiful native timber of New Zealand sourced from sustainably-managed forests. If your wheel is natural timber it should be protected as soon as possible to avoid staining from lubricants & provide protection from any climatic changes. We recommend Ashford Teak Wax, however any reputable wood oil or wax finish would be suitable. Factory lacquered wheels may be further enhanced with our Teak Wax finish.

How do I stop the clunking sound on my older Traditional?

On older wheels we used a 1/8" (2-3cm) diameter silver steel hub pin which wears the hole in the crank. A simple but temporary solution is to remove the hub pin and hit it with a hammer so that it has a slight banana shape. Then tap it back into the hole. A better and permanent solution is to order a "Clunky Wheel Kit" from your local Ashford dealer. This kit includes a new crank, hub pin and con rod. It's easy to fit and will make for silent spinning.

The best option (apart from buying a new Ashford wheel) is to fit a "Double Treadle Kit" which includes the parts mentioned above plus double treadles to make for effortless and quiet spinning.

How do I stop my flyer vibrating on my Traveller?

Tighten the 2 bolts holding the main uprights to the base, the 2 screws holding the top rail to the main uprights, all the hinge screws & the screws holding the 2 maiden uprights to the maiden bar. Completely loosen the drive belt adjusting knob, place the drive band in the appropriate groove in the flyer whorl & retie the drive cord. If none of these steps help then check the flyer for balance. Remove one hook from one side of the flyer & treadle. If the vibration is reduced but still there then try removing another & so on. If it is worse then replace & remove hooks from the opposite side until it is vibration free. The side that still has all its hooks is lighter & needs additional weight to balance it. Either push 1 or 2 thumb tacks into the underside of the light side of the flyer arm for every flyer hook removed or for a more aesthetic result add small wood screws.